

# Type 243

## 2.4 Meter Offset Transmit Receive Antenna System

---

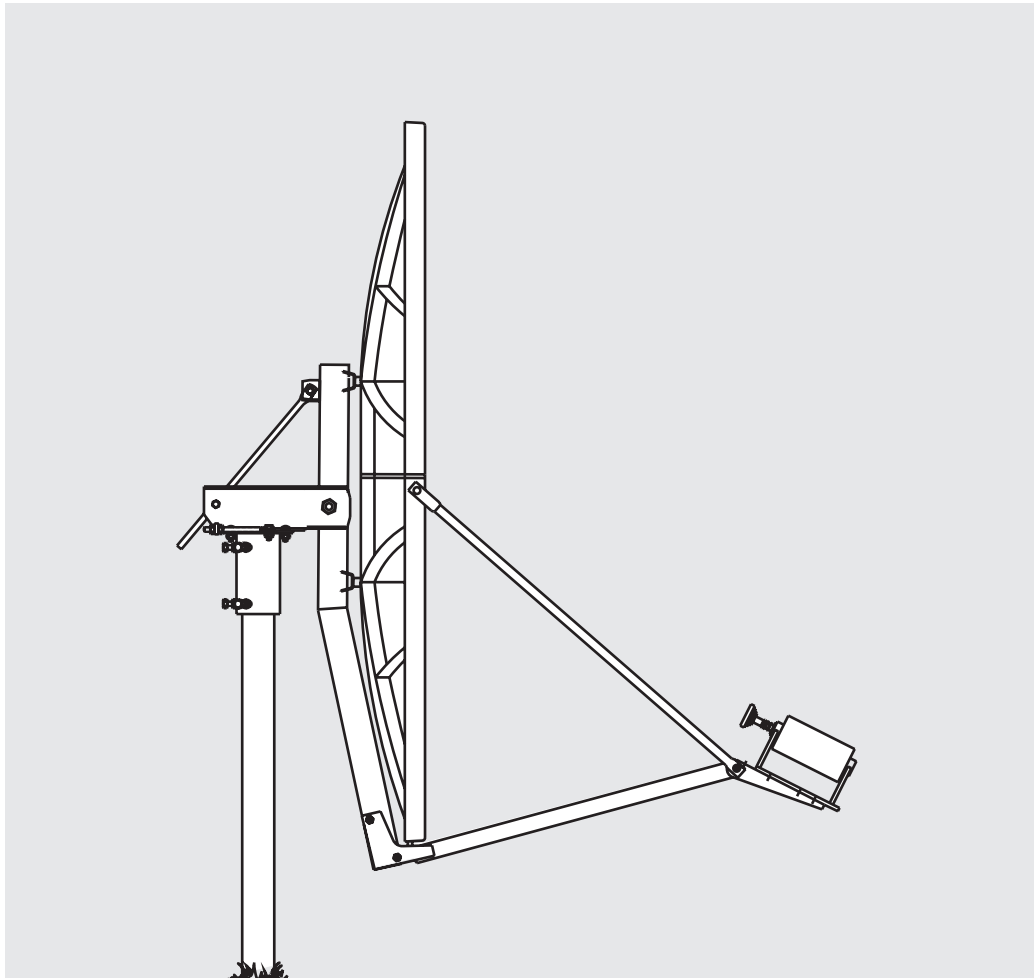

Andrew Corporation  
3 Westbrook Corporate Center  
Suite 900  
Westchester, Illinois 60154 USA

One Company. A World of Solutions.

Customer Support Center  
From North America  
Telephone: 1-800-255-1479  
Fax: 1-800-349-5444  
satcom@andrew.com

International  
Telephone: +1-708-873-2307  
Fax: +1-708-349-5444  
Internet: [www.andrew.com](http://www.andrew.com)

Printed in U.S.A.

02/07 8000450-03 Rev B

## MANUAL REVISION HISTORY

DATE	DESCRIPTION	REVISION
3/04	ECN 9000000	Release
9/04	ECN 9006903	
9/05	ECN 9007185	
11/05	ECN 9007242	
02/07	5064790	Rev B

## WARRANTY

### ANDREW CORPORATION VERY SMALL APERTURE TERMINAL (VSAT) PRODUCTS TWELVE (12) MONTH LIMITED WARRANTY

Seller warrants that all ANDREW manufactured VSAT products are transferred rightfully and with good title; that they are free from any lawful security interest or other lien or encumbrance unknown to Buyer. Seller also warrants that for a period of twelve (12) months from the date of shipment from Seller's factory, all its VSAT products shall be free from defects in material and workmanship which arise under proper and normal use and service. Buyer's exclusive remedy hereunder is limited to Seller's correction (either at its plant or at such other place as may be agreed upon between Seller and Buyer) of any such defects by repair or replacement at no cost to Buyer, except for the costs of any transportation in connection with the return of the defective VSAT products to be replaced or repaired, and the costs to remove and/or reinstall the products, which shall be borne by Buyer. The limited warranty period shall not be extended beyond its original term with respect to any part or parts repaired or replaced by seller hereunder.

This warranty shall not apply to VSAT products which (i) have been repaired or altered in any way so as to affect stability or durability, (ii) have been subject to misuse, negligence or accident, (iii) have been damaged by severe weather conditions such as excessive wind, ice, storms, lightning, or other natural occurrences beyond Seller's control; (iv) have presented damages, defects or nonconformances caused by improper shipping, handling or storage, and (v) have not been installed, operated or maintained in accordance with Seller's instructions.

Buyer shall present any claims along with the defective VSAT product(s) to Seller immediately upon failure. Non-compliance with any part of this warranty procedure may invalidate this warranty in whole or in part.

SELLER MAKES NO WARRANTY, EXPRESS OR IMPLIED, OTHER THAN AS SPECIFICALLY STATED ABOVE. EXPRESSLY EXCLUDED ARE ANY IMPLIED WARRANTIES OF MERCHANTABILITY OR FITNESS FOR A PARTICULAR PURPOSE. THE FOREGOING SHALL CONSTITUTE ALL OF SELLER'S LIABILITY (EXCEPT AS TO PATENT INFRINGEMENT) WITH RESPECT TO THE VSAT PRODUCTS. IN NO EVENT SHALL SELLER BE LIABLE FOR ANY LOSS OF PROFITS OR REVENUE, LOSS OF USE, INTERRUPTION OF BUSINESS, OR INDIRECT, SPECIAL, CONSEQUENTIAL OR INCIDENTAL DAMAGES OF ANY KIND AS A RESULT OF THE USE OF THE PRODUCTS MANUFACTURED BY SELLER, WHETHER USED IN ACCORDANCE WITH THE INSTRUCTIONS OR NOT. UNDER NO CIRCUMSTANCES SHALL SELLER'S LIABILITY TO BUYER EXCEED THE ACTUAL SALES PRICE OF THE VSAT PRODUCTS HEREUNDER.

In some jurisdictions, Buyer may have other rights under certain statutes that may imply non-excludable warranties. No representative is authorized to assume for Seller any other liability in connection with the VSAT products.



#### DO NOT DISCARD CONTENTS

The product in this packaging was placed in the market after August 13, 2005. Its components must not be discarded with normal municipal or household waste.

Contact your local waste disposal agency for recovery, recycling, or disposal instructions.

## WARNINGS

**LAW:** Installation and installer must meet local codes and ordinances regarding safety! Installation of this product should be performed only by a professional installer and is not recommended for consumer Do-It-Yourself installations.

**DANGER:** **WATCH FOR WIRES!** Installation of this product near power lines is extremely dangerous and must never be attempted. Installation of this product near power lines can result in death or serious injury!

For your own safety, you must follow these important safety rules. Failure to follow these rules could result in death or serious injury!

1. Perform as many functions as possible on the ground
2. Watch out for overhead power lines. Check the distance to the power lines before starting installation. Stay at least 6 meters (20 feet) away from all power lines.
3. Do not install antenna or mast assembly on a windy day.
4. If you start to drop antenna or mast assembly, move away from it and let it fall.
5. If any part of the antenna or mast assembly comes in contact with a power line, call your local power company. **DO NOT TRY TO REMOVE IT YOURSELF!** They will remove it safely.
6. Make sure that the mast assembly is properly grounded.

**WARNING:** Assembling dish antennas on windy days is extremely dangerous and must never be attempted. Due to the surface area of the reflector, even slight winds create strong forces. For example, this antenna facing a wind of 32 km/h (20 mph) can undergo forces of 269 N (60 lb). **BE PREPARED TO SAFELY HANDLE THESE FORCES AT UNEXPECTED MOMENTS. ATTEMPTING TO ASSEMBLE, MOVE OR MOUNT A DISH ON WINDY DAYS COULD RESULT IN DEATH OR SERIOUS INJURY.** ANDREW is not responsible or liable for damage or injury resulting from antenna installations.

**WARNING:** Antennas improperly installed or installed to an inadequate structure are very susceptible to wind damage. This damage can be very serious or even life threatening. The owner and installer assumes full responsibility that the installation is structurally sound to support all loads (weight, wind and ice) and properly sealed against leaks. ANDREW will not accept liability for any damage caused by a satellite system due to the many unknown variable applications.

## PRE INSTALLATION CONSIDERATIONS

### DESCRIPTION:

The 2.4 Meter Offset Transmit-Receive Antenna System is designed for two-way satellite communications, and is suitable for commercial or consumer use.

### TOOLS REQUIRED:

Compass	19 mm or 3/4 in Deep Socket (1/2 in or 13 mm Drive)
Clinometer	Ratchet Wrench (1/2 in or 13 mm Drive)
228 mm or 9 in Magnetic Bubble Level	10 mm Nut Driver
Torque Wrench (Capacity 5 - 237 N-m) (4 - 175 ft-lb)	10 mm Box/Open End Wrench
	12 in Adjustable Crescent Wrench
24 mm or 15/16 in Deep Socket (1/2 in or 13 mm Drive)	10 mm Socket (For Torque Wrench)
	32 mm or 1-1/4 in Deep Socket (1/2 in or 13 mm Drive)

### ADDITIONAL INSTALLATION MATERIALS (Not Included with Antenna)

Grounding Rod, Clamp & Grounding Block - As required by National Electric Code or local codes.

Ground Wire - #10 solid copper or #8 aluminum as required by National Electric Code or local codes (length required).

RG-6 Coaxial Cables from antenna to indoor unit(s).

Concrete: See "Ground Pole" section for quantity

M10 or #3 Rebar: See "Ground Pole" section for quantity. Deformed steel per ASTM A615, Grade 40 or 60.

## SITE SELECTION

The first and most important consideration when choosing a prospective antenna site is whether or not the area can provide an acceptable "look angle" at the satellites. A site with a clear, unobstructed view is preferred. Also consider obstruction that may occur in the future such as the growth of trees. Your antenna site must be selected in advance so that you will be able to receive the strongest signal available. To avoid obstructions, etc., conduct an on-site survey with a portable antenna.

As with any other type of construction, a local building permit may be required before installing an antenna. It is the property owner's responsibility to obtain any and all permits.

Before any digging is done, information regarding the possibility of underground telephone lines, power lines, storm drains, etc., in the excavation area should be obtained from the appropriate agency.

Because soils vary widely in composition and load capacity, consult a local professional engineer to determine the appropriate foundation design and installation procedure. A suggested foundation design with conditions noted is included in this manual for reference purposes only (see page 4). To assist in the foundation design, refer to "Antenna Wind loads" in the Appendix "B" on page 11.

## BOLT TORQUE

DIN CLASS 5.6						DIN CLASS 8.8		
M6	M8	M12	M16	M20	M22	M8	M12	M16
5 N-m	15 N-m	51 N-m	125 N-m	168 N-m	230 N-m	24 N-m	90 N-m	203 N-m
4 ft-lb	11 ft-lb	38 ft-lb	92 ft-lb	24 ft-lb	170 ft-lb	18 ft-lb	66 ft-lb	150 ft-lb

Head marking 5.6 or 8.8, if no head marking use DIN Class 5.6 values in above chart.

### EXCEPTIONS TO ABOVE CHART:

- M16 x 140 mm round head square neck bolts securing antenna to mount. Torque to 47 N-m (35 ft-lb).
- M12 x 40 mm hex head bolts securing antenna halves. Torque to 47 N-m (35 ft-lb).

# GROUND POLE INSTALLATION (168.3 mm or 6.63 in)

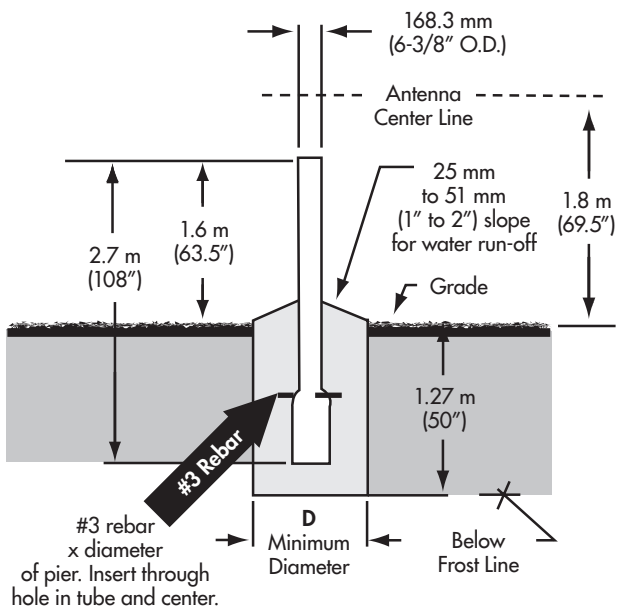

**Pier Foundations**

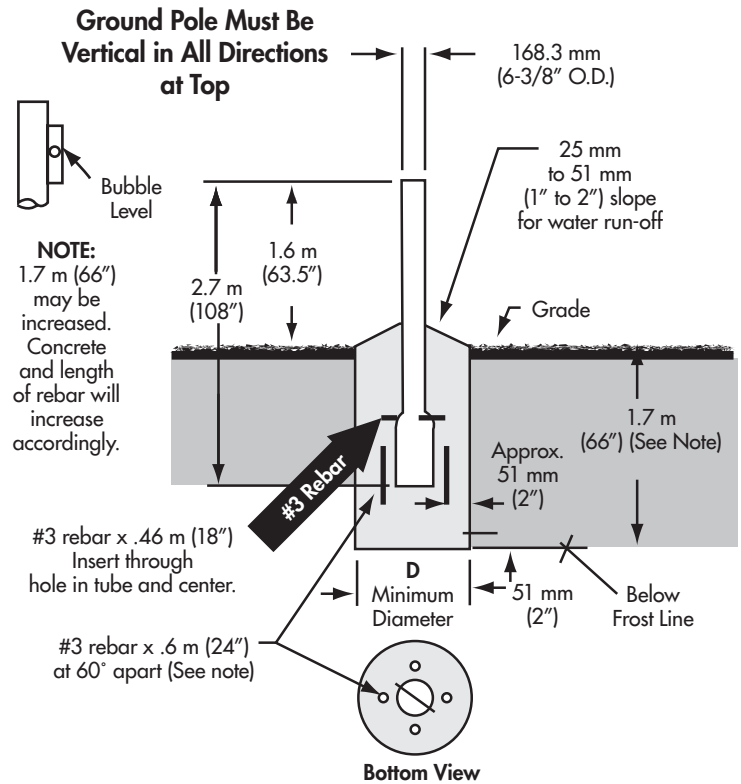

**Deep Frost Line Foundations**

WIND VELOCITY	DIMENSION D Meter (Inches)	CONC VOLUME Cubic Meter (CUYD)	DIMENSION D Meter (Inches)	CONC VOLUME Cubic Meter (CUYD)	GROUND POLE
100 mph	1.12 (44)	1.3 (1.7)	.94 (37)	1.2 (1.6)	A
125 mph	1.35 (53)	1.8 (2.4)	1.15 (42.25)	2.0 (2.6)	B

## POLE SPECIFICATIONS:

Ground Pole "A"- 6.62 O.D. SCH 40 (6.06 I.D.) Steel - (Metric = 168.3 mm x 153.9 mm I.D.)

Ground Pole "B"- 6.62 O.D. SCH 80 (5.76 I.D.) Steel - (Metric = 168.3 mm x 146.3 mm I.D.)

## NOTE:

- Poles are not supplied (purchased locally to ASTM A501) and must be field drilled 5/8 diameter for M10 #3 rebar, drilled 5.55 mm (.218") for 1/4-20 self tapping grounding screw and galvanized or painted for protection.
- Pole and foundation design based on the following criteria:
  - Uniform building code Exposure C and 1.5 stability factory.
  - Vertical soil pressure of 2000 pounds per square foot. (9765 Kilograms/meter square)
  - Lateral soil pressure of 300 pounds per square foot. (1465 Kilograms/meter square)
  - Concrete compressive strength of 2500 pounds per square inch (176 Kg/cm<sup>2</sup>) in 28 days.

**CAUTION:** The foundation design shown does not represent an appropriate design for any specific locality, since soil conditions vary and may not meet design criteria given in Note 2. You should consult a local professional engineer to determine your soil conditions and appropriate foundation.

## ASSEMBLY AND INSTALLATION

Place reflector halves on a flat surface, face down. Install M12 x 40 mm hex bolts (44) with flat washer (45) into the two outer bolt holes at reflector rim. Secure with M12 flat washer (45), lock washer (3) and hex nut (4) as shown below. Repeat on opposite side of reflector. Leave loose.

Install remaining seam bolts, working toward center of reflector as noted above. Repeat on opposite side of reflector. Leave finger tight.

**NOTE:** All seam bolts to be finger tight only.

**NOTE:** Assemble hardware starting at outer bolt holes and work toward center of reflector. Repeat process on opposite side of reflector.

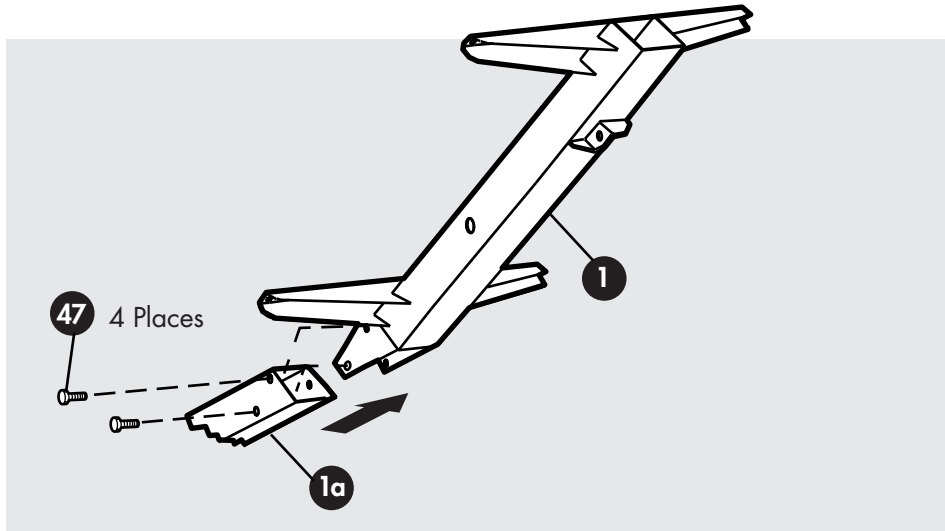
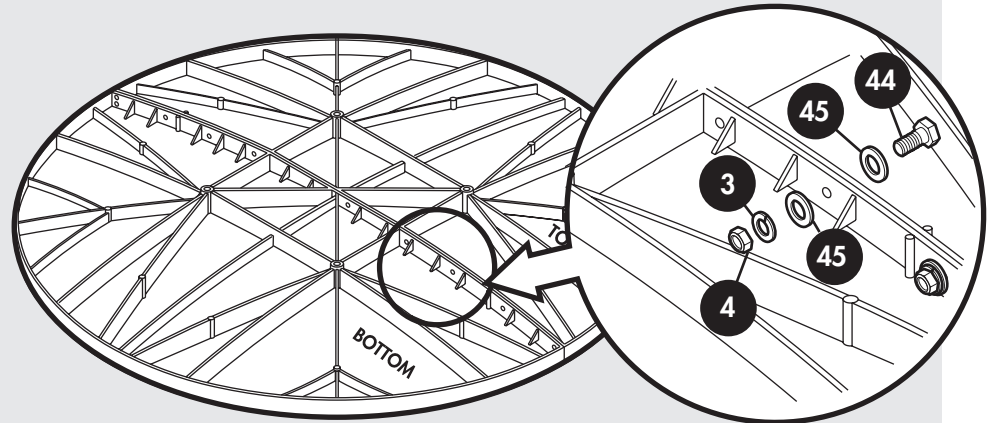

### Backframe Tube

Assemble bottom tube (1a) to backframe (1) with four M12 x 19 mm hex bolts (47), as shown.

Torque to 47-54 N-m (35-40 ft-lb).

### Yoke Cap Assembly

Push M16 x 35 mm round head square neck pivot bolt through center square hole in cap top plate (30) and attach channel assembly (31). Secure with M16 hex nut and lock washer, torque to 11-15 N-m (8-11 ft-lb). Install four M12 x 35 mm round head square neck bolts, flat washers, lock washers and hex nuts in channels (31) bottom flange and cap top plate (30). Connect flat end of azimuth screw to cap top plate (30) with M12 x 30 mm hex head bolt, lock washer and hex nut. Torque all M12 x 35 mm round head square neck bolts to 11-15 N-m (8-11 ft-lb).

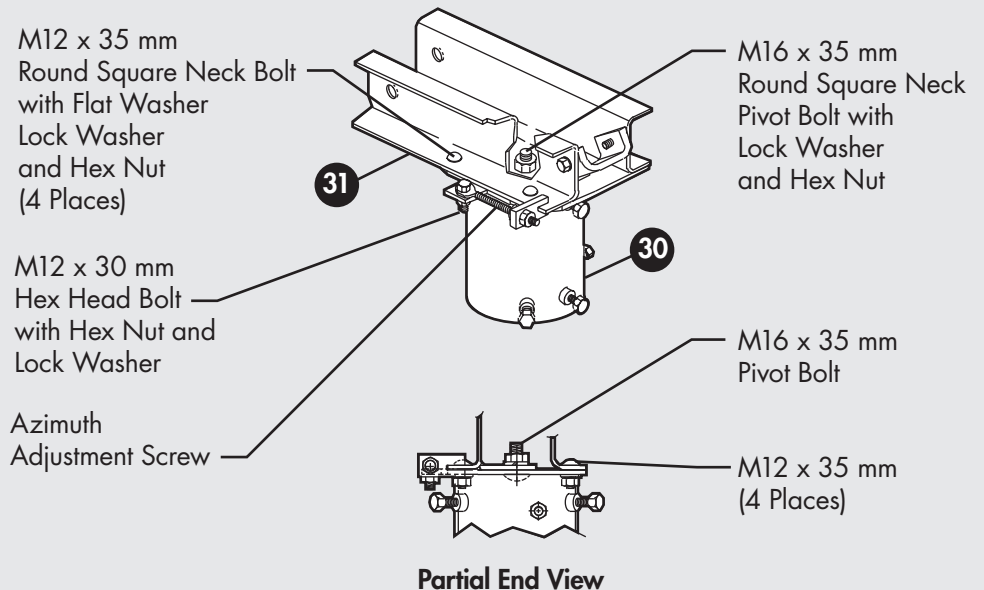

## Yoke Cap and Backframe Assembly

Place yoke cap assembly onto ground pole.

Install backframe (1) onto yoke cap assembly and secure with M22 x 150 mm hex bolt, lock washer and hex nut (24, 15 & 14). Do not tighten. Remove two M12 bolts from trunnion, swing backframe down and secure elevation screw and trunnion (25 & 26) to AZ/EL cap with M12 x 30 mm hex bolt and lock washer (17 & 3). Leave loose.

Loosen M22 elevation nuts (14) on elevation screw (25) and run up to place backframe in bird bath position.

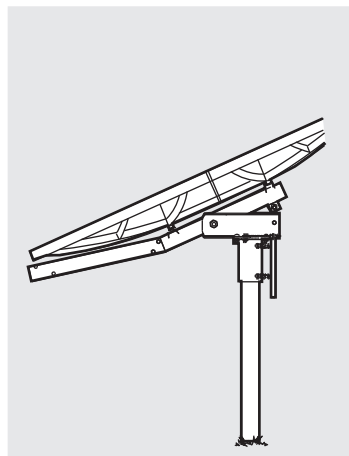
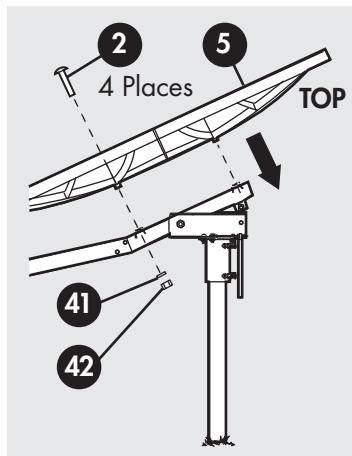
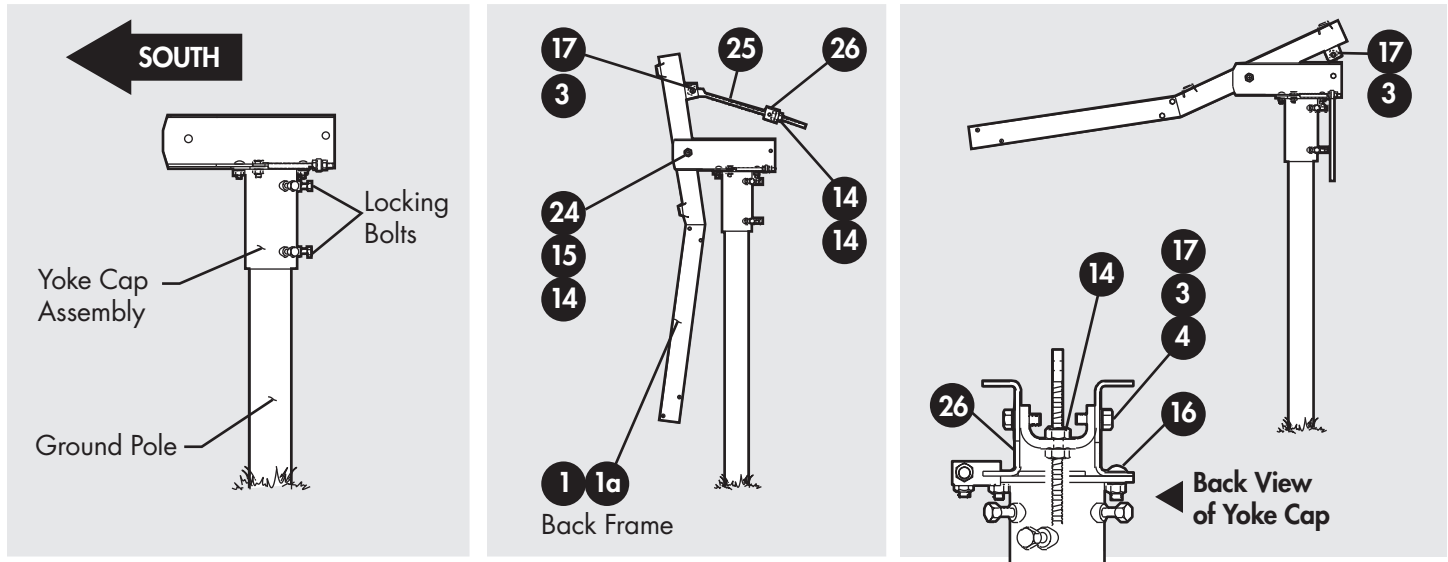

### Antenna Installation

Insert four M16 x 140 mm round head square neck bolts (2) into reflector assembly (5) and affix on to backframe.

Reflector section marked "TOP" must be located at the top end of backframe. Make sure round head square neck bolts are seated correctly before securing reflector to backframe. Secure reflector to backframe with M16 lock washers and hex nuts. **Leave these bolts loose.**

### Seam Alignment

Lower reflector to vertical position by running down two elevation nuts (14). Check the horizontal seam match as shown below. If alignment is required, begin at the outer rim by pushing or pulling on the bottom reflector rim, while another tightens their seam bolts at this location. Continue this process, working toward the center, and alternating from one side to the other. After all seam bolts are tightened, torque bolts, using the same sequences as above, to 47 N-m (35 ft-lb). Now tighten and torque four reflector mounting bolts (2) to 47 N-m (35 ft-lb). Torque cross arm (1a) bolts (47) per chart, Page 3, three places and lower bolt (47) one place to 81 N-m (60 ft-lb). **NOTE:** Certain models require additional alignment instructions. Refer to supplement for detailed instructions.

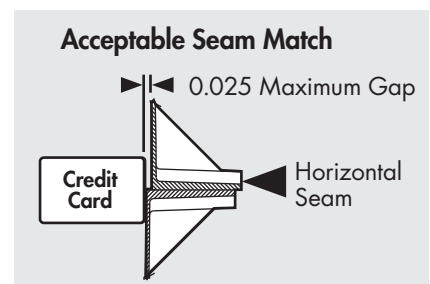
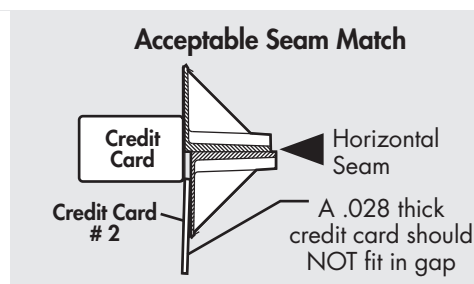
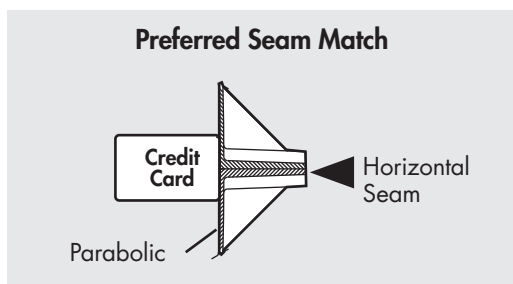

## Feed Support Tube

Install M6 x 40 mm hex bolt with flat washer (46 & 7) into bottom hole in reflector and secure with M6 flat washer and hex nut (7 & 6). **Reference Figure 1.1.** Install feed support tube (10) onto backframe and secure with two M12 x 130 mm hex bolts, four external tooth lock washers and hex nuts (12, 11 & 4). **Reference Figure 1.2. IMPORTANT:** M6 x 40 mm hex gage bolt (46) in bottom of reflector fits into hole on top of support tube end (10). **Reference Figure 1.2. NOTE:** M12 external tooth washers (11) must be assembled on bolts, with one under head of bolt and one under hex nut (4), refer to **Figure 1.2.** Leave these bolts loose.

Install left and right side struts onto reflector as shown in **Figure 1.3.**

Attach long formed end of side struts (27) to reflector rim by inserting M6 x 20 mm hex head bolt (28) through inside of reflector rim and secure snug, but free to pivot with M6 lock washer and hex nut (6 & 8). Attach short formed end of side struts (27) to feed support tube with M6 x 20 mm hex bolt, lock washer and hex nut (28, 8 & 6). **Reference Figure 1.3.** Tighten and torque hardware securing side struts to feed support tube only to 8 N-m (6 ft-lb). Without using excessive pressure, lift feed support tube vertically just enough to relieve load off side struts and bottom rim gage bolt (46). While another person tightens and torques M12 hex head bolts (\*) securing feed support tube to backframe to 47 N-m (35 ft-lb). Tighten and torque M6 hex head bolts (\*\*) securing side struts to reflector to 5.4 N-m (4 ft-lb). **Reference Figure 1.4.** To install ODU or feeds, see instructions supplied with these kits.

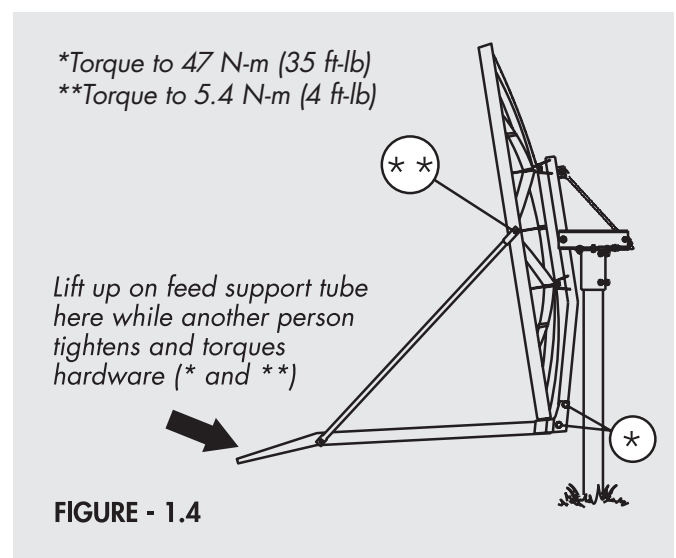
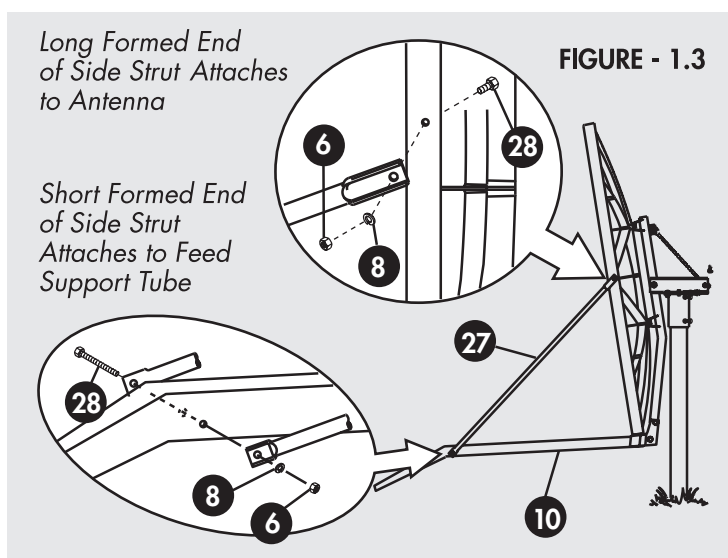
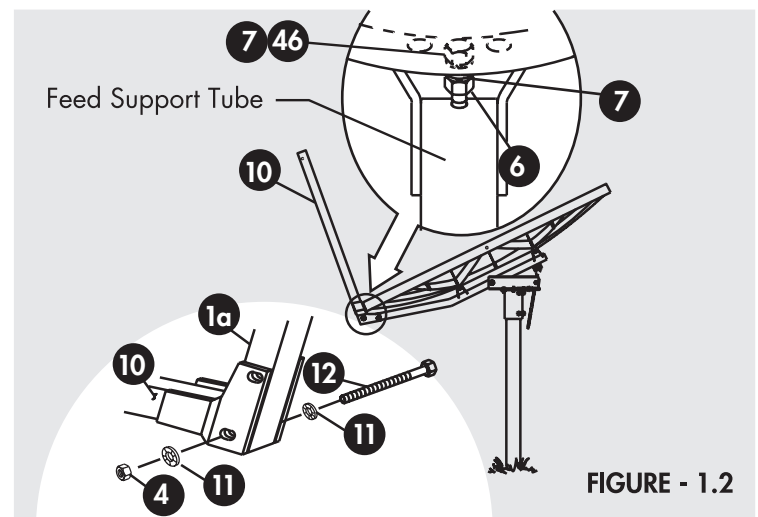
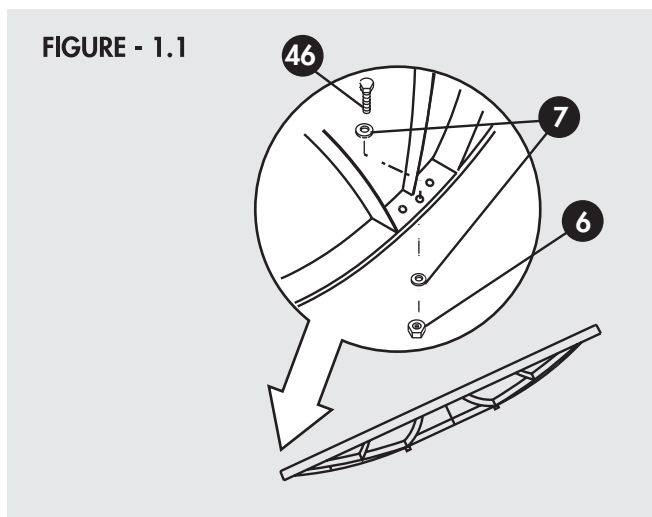



## GROUNDING INSTRUCTION FOR GROUND POLE

**NOTE:** All installations to conform to the latest issue of the National Electric Code and local codes.

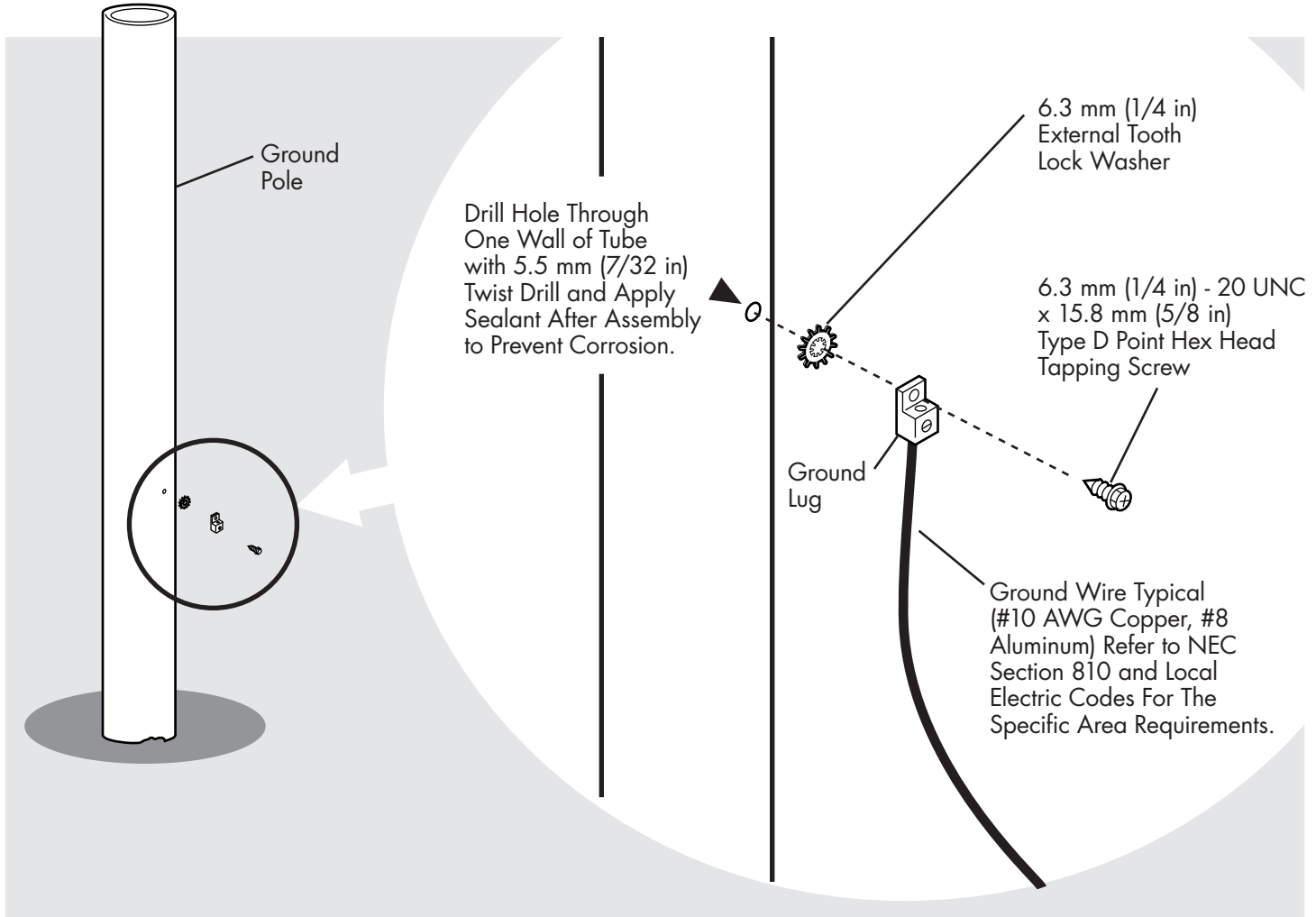

**NOTE:** All installations to conform to latest issue of National Electrical Code. Ground antenna mount assembly and feed cables in accordance with current National Electrical code and local codes.

These illustrations depict typical grounding methods for the ground pole and feed cables. Clamps that provide a solid connection between ground wire and ground source should be used. Tighten and torque all hardware.

### Cable Grounding Components Are Not Supplied

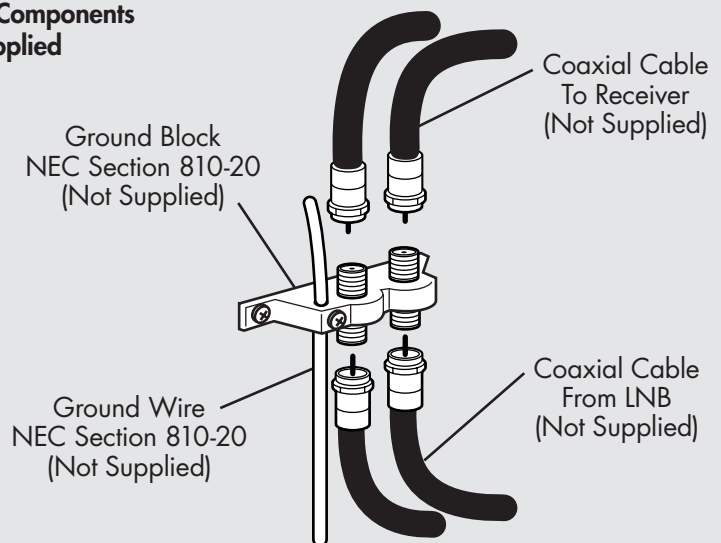

# ANTENNA ALIGNMENT PROCEDURE

## Satellite Alignment

Alignment with the satellite is obtained by setting polarization, elevation, and azimuth. Charts are provided on page 12, 13 and 14 to determine the values for your earth station antenna site. " $\Delta L$ " is the difference between the earth station antenna site longitude and the satellite longitude. Use " $\Delta L$ " and your earth station latitude to obtain polarization, elevation or azimuth setting.

## Polarization of Feed

Loosen feed horn clamp bolts and turn feed clockwise or counter clockwise, depending on being east or west of the satellite as shown in Polarization Chart on page 12. Align marks on the horn clamp and appropriate mark on the horn scale. Polarization chart assumes antenna system polarization is transmit vertical and satellite vertical Pol is perpendicular to plane of geostationary arc. For horizontal transmit of antenna, feed must be rotated  $90^\circ$  from values shown. (Starting point for polarization adjustment is  $0^\circ$ ).

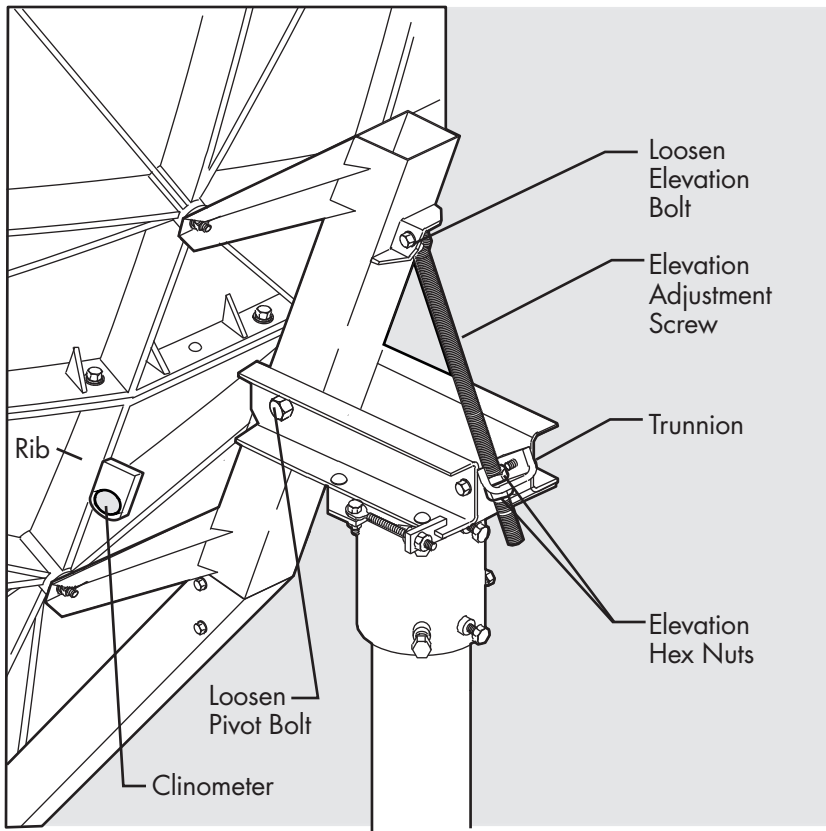
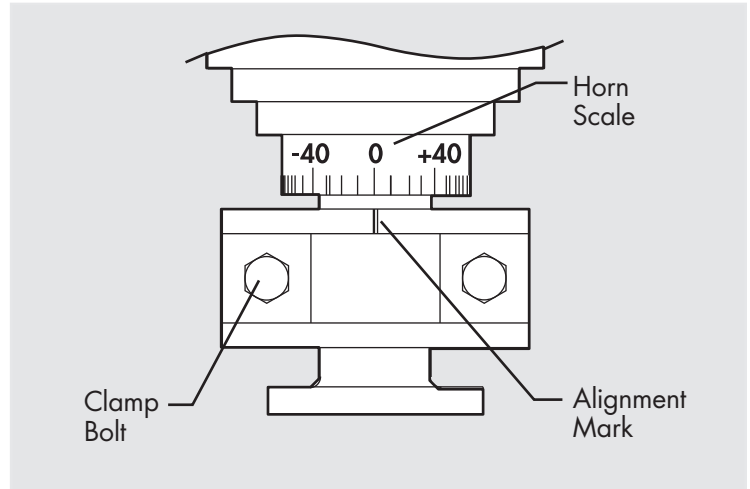

## Elevation Alignment

Use Elevation Chart on page 13 and determine your elevation setting. Using a clinometer, adjust the elevation by turning the elevation screw adjusting nuts until the desired elevation is obtained.

**Note:** Degree values shown on the clinometer are mechanical. When the reflector face is vertical, mechanical elevation is  $90^\circ$  or axis is  $0^\circ$ , while the beam elevation (signal) axis is  $22.62^\circ$ . Therefore, as the reflector is tilted, remember to compensate for the  $22.62^\circ$  offset angle to get the correct beam elevation. (See Appendix A, Outline Drawing, Page 17). This is an approximate setting. Optimum setting will be achieved during the fine tuning.

## Azimuth

Use Azimuth Chart on page 14 and determine your azimuth setting. Values in chart must be adjusted for magnetic deviation for your location for correct compass reading.

Equally tighten the six azimuth locking bolts until snug. This will allow the reflector to rotate with slight resistance.

Rotate reflector and mount, pointing to the compass reading for your location. Slowly sweep the reflector in azimuth until signal is found. If desired signal is not found, increase or decrease elevation setting and repeat the azimuth sweep. Tighten locking bolts.

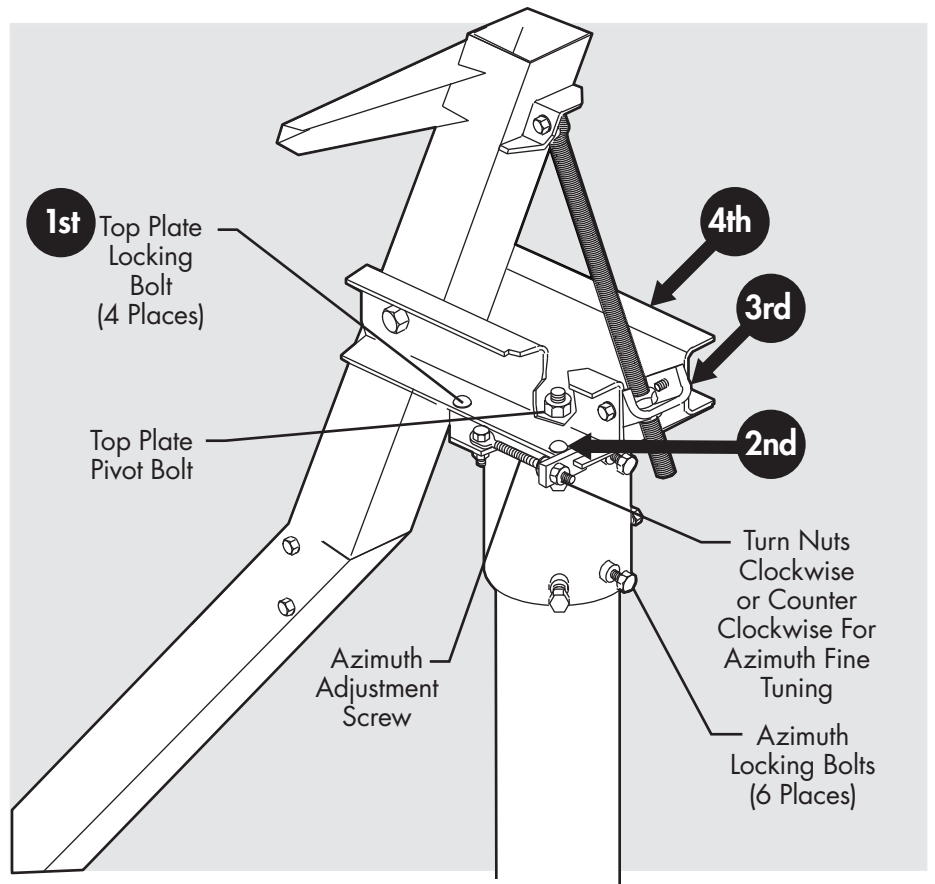

## Fine Tuning

Progressively tighten and torque azimuth locking bolts to 100-115 N-m (75-85 ft-lb). The four top plate locking bolts are pre-torqued to 11-15 N-m (8-11 ft-lb). Maintain this torque until after azimuth is fine tuned.

Use a signal strength measuring device for final adjustments to obtain maximum antenna performance. Alternate between elevation and azimuth fine tuning to reach maximum signal strength, until no improvement can be detected. Gradually tighten (1/8 turn increments max.) top plate bolts in sequence 1st, 2nd, 3rd and 4th to 100 N-m (75 ft-lb). Observe for maximum signal strength as elevation screws M22 locking nuts are tightened.

Polarization tune may be checked by slowly rotating feed assembly in clamp. When maximum signal strength is found, gradually tighten clamp bolts. If a signal on the opposite polarity is available, this signal should be minimized.

Tighten and torque all hardware. Refer to Torque Chart on Page 3.

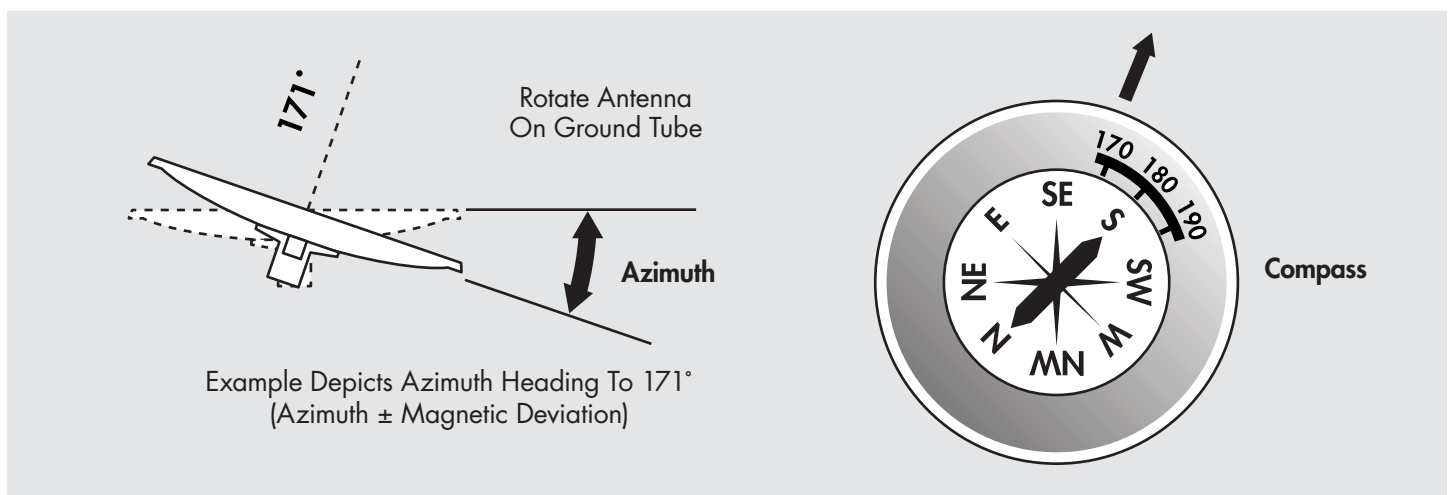

## APPENDIX B

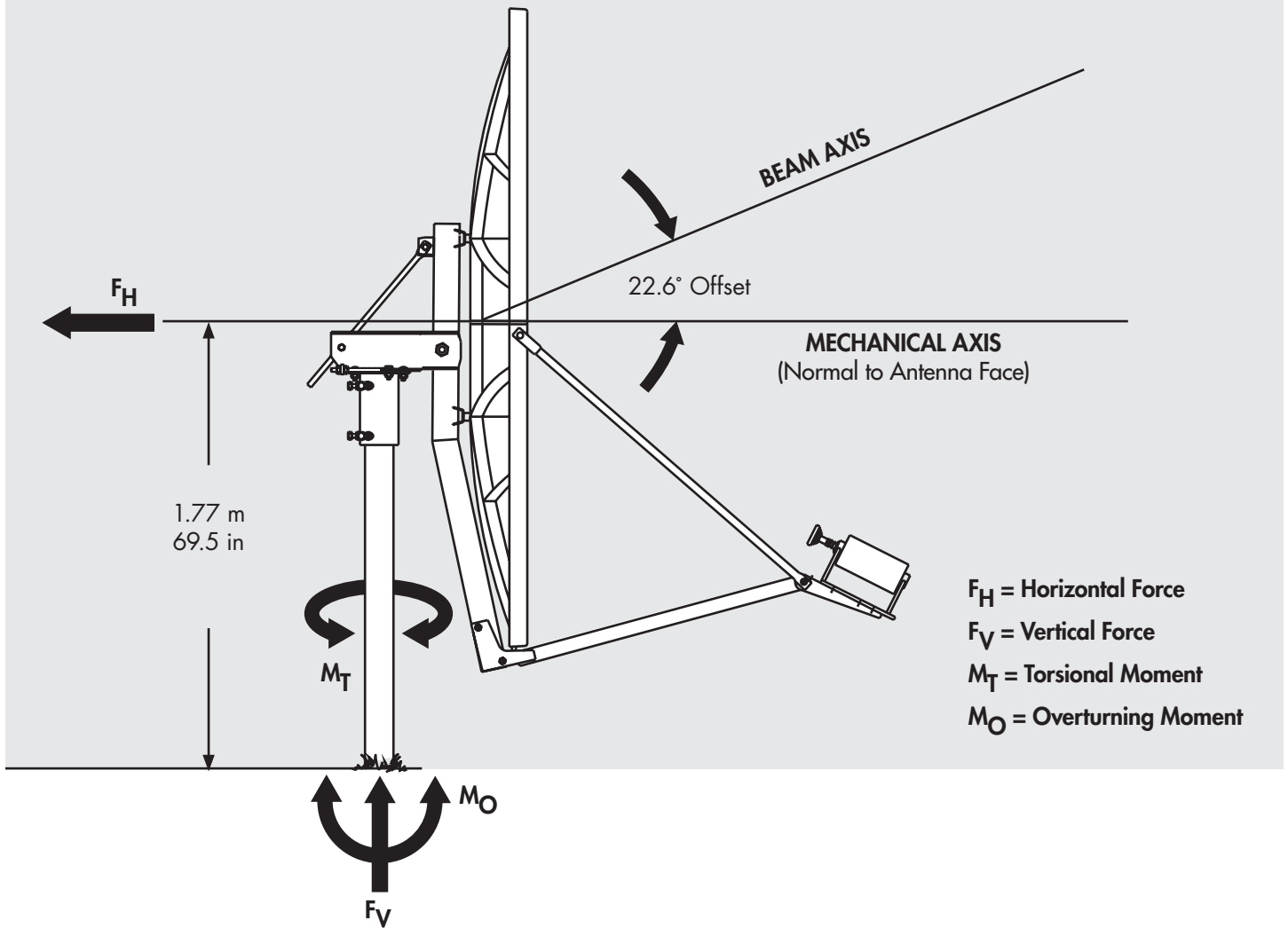

Elevation Degrees		Force N (Pounds)		Moments N-m (Foot-Pounds)	
Mechanical	Beam	$F_H$	$F_V$	$M_T$	$M_O$
0	23	14,813 (3,330)	-396 (-89)	3,541 (2,612)	26,148 (19,286)
10	33	14,021 (3,152)	-2,963 (-666)	3,467 (2,557)	24,750 (18,255)
20	43	13,629 (3,064)	-5,729 (-1,288)	3,289 (2,426)	24,060 (17,746)
30	53	12,344 (2,775)	-8,198 (-1,843)	2,986 (2,202)	21,790 (16,072)
40	63	10,863 (2,442)	-9875 (-2,220)	2,531 (1,867)	19,175 (14,143)
50	73	9,479 (2,131)	-10,863 (-2,442)	2,126 (1,568)	16,734 (12,342)
60	83	7,900 (1,776)	-11,356 (-2,553)	1,645 (1,213)	13,946 (10,286)
70	93	5,925 (1,332)	-8,790 (-1,976)	1,265 (933)	10,460 (7,715)

# POLARIZATION CHART

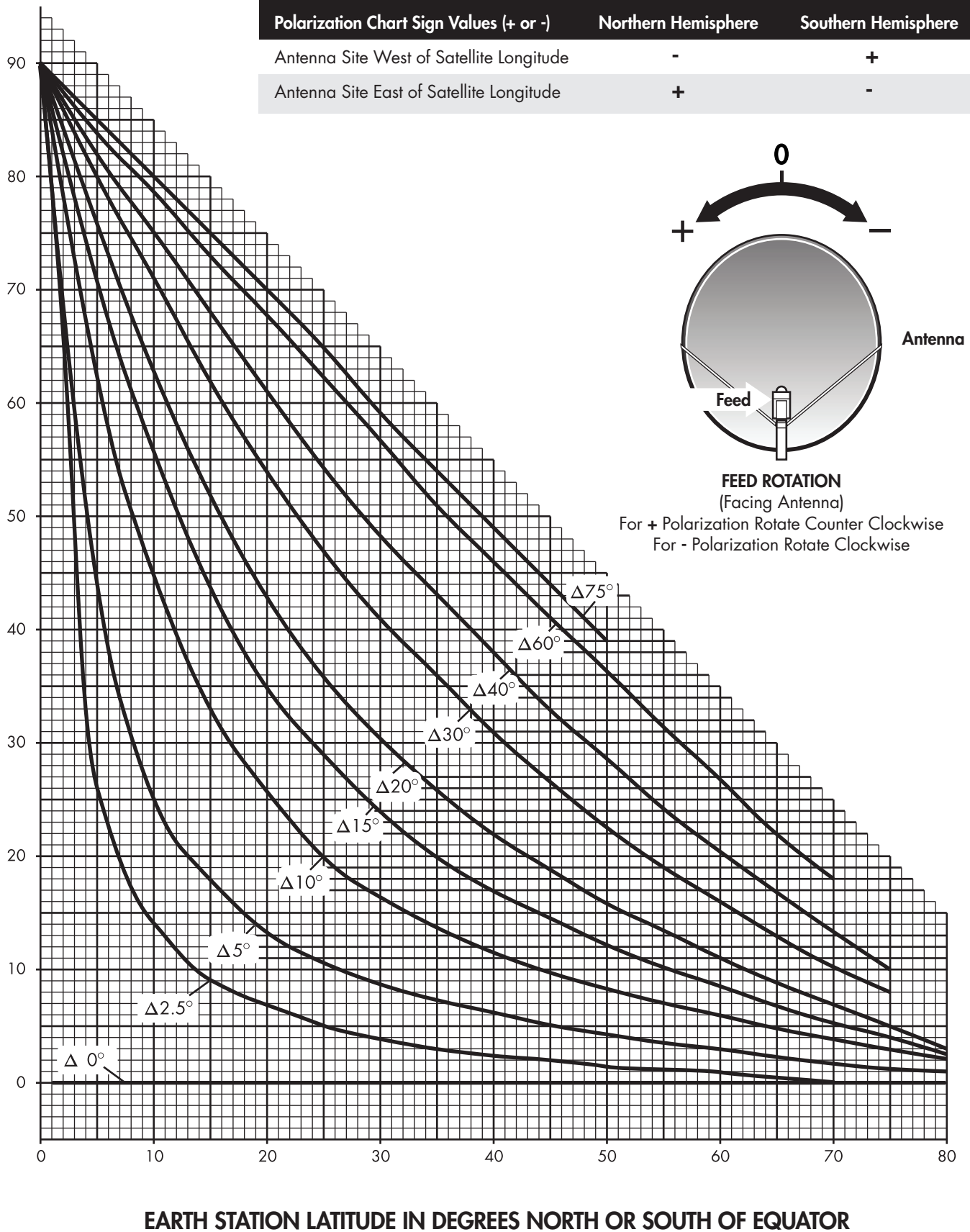

# ELEVATION CHART

## Use of Elevation Chart

- Determine  $\Delta$  = the difference between your site longitude and the satellite longitude.
- Find your latitude on horizontal axis.
- Follow your latitude up until you intersect the curve for your  $\Delta$ .
- Read Elevation value on vertical axis.

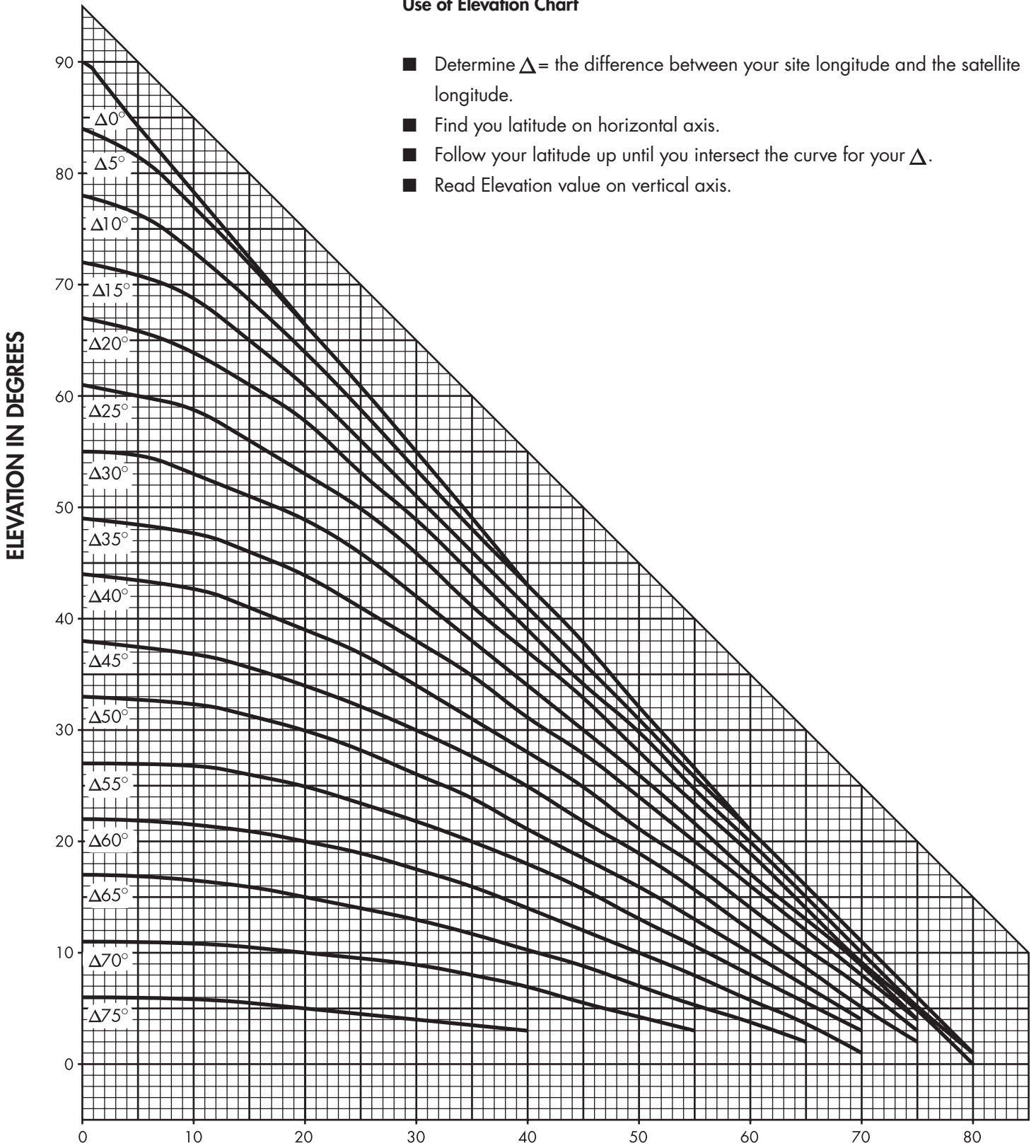

# AZIMUTH CHART

" $\Delta$ " IS THE DIFFERENCE BETWEEN THE EARTH STATION ANTENNA SITE LONGITUDE AND THE SATELLITE LONGITUDE

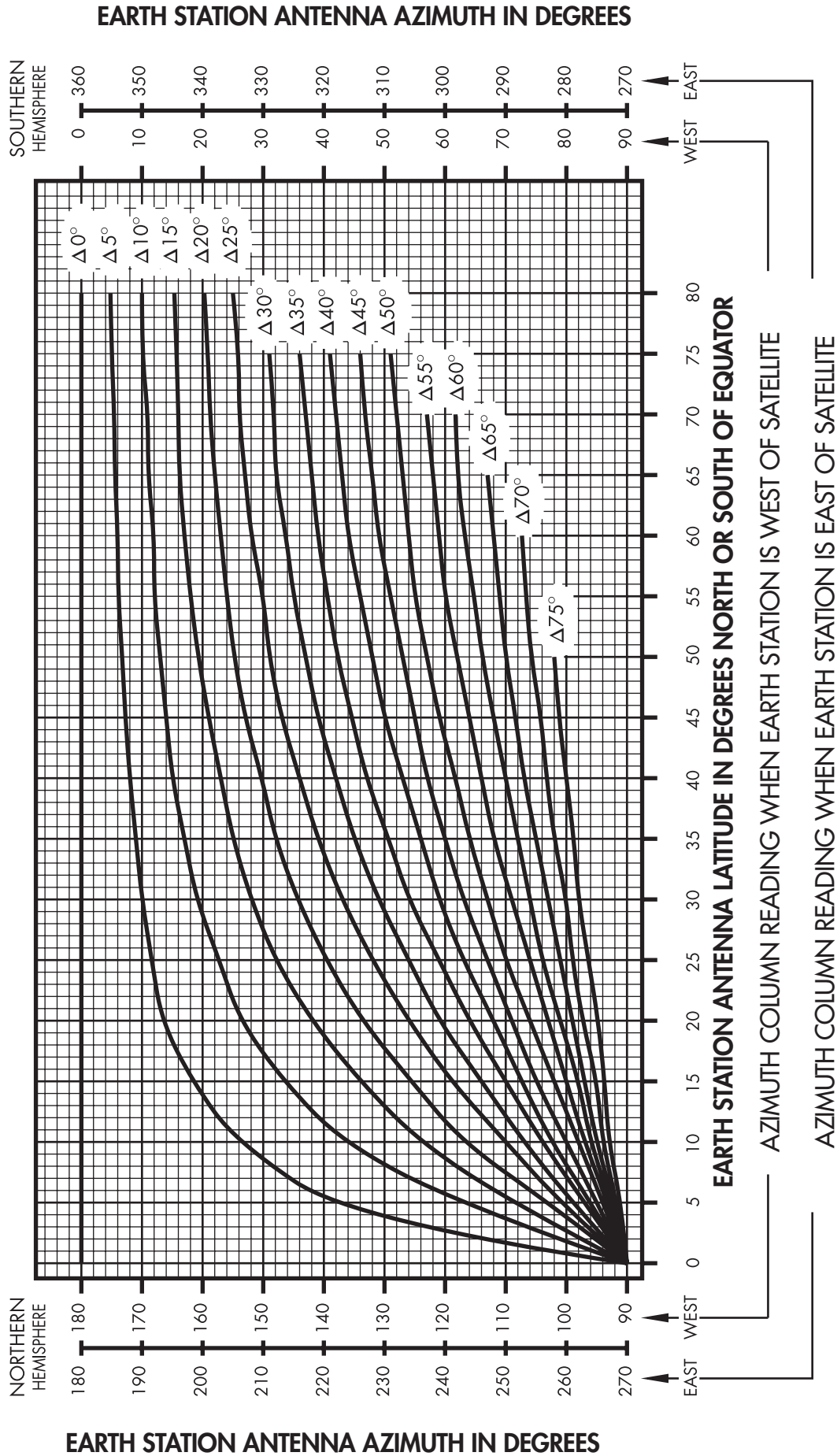

# PARTS LIST

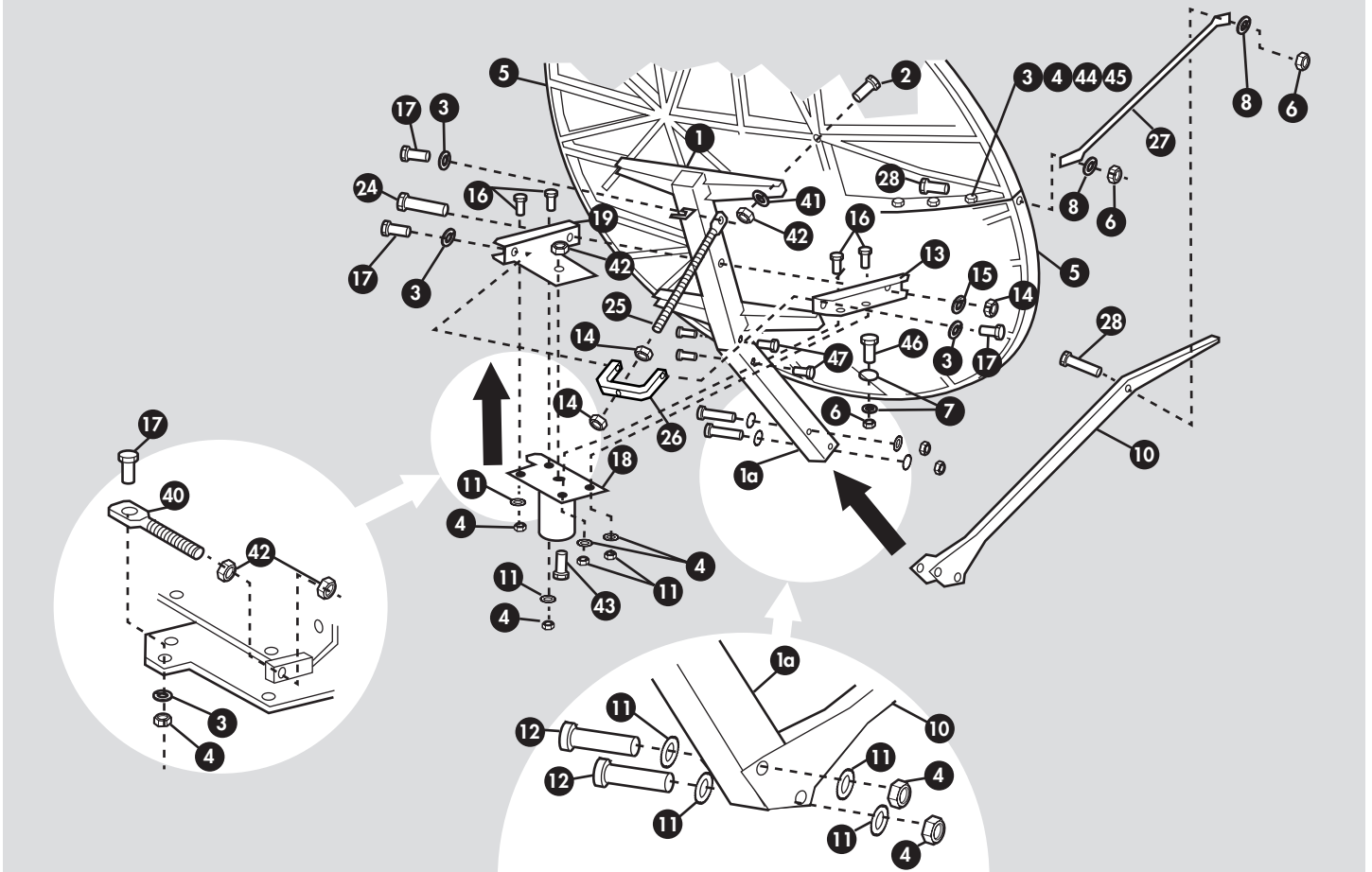

NO.	DESCRIPTION	QTY.	NO.	DESCRIPTION	QTY.
1	Galvanized Backframe Tube Weldment	1	25	M22 Elevation Adjustment Screw	1
1a	Backframe Lower Tube Weldment	1	26	Galvanized Trunnion	1
2	Galvanized M16 x 140 mm Round Head Square Neck Bolt	4	27	Side Strut	2
3	Galvanized M12 Lock Washer	20	28	M6 x 20 mm Stainless Steel Hex Bolt	4
4	Galvanized M12 Hex Nut	19	40	Azimuth Adjustment Screw	1
5	2.4 Meter SMC Antenna Top Half (Transmit Quality)	1	41	Galvanized M16 Lock Washer	4
-	2.4 Meter SMC Antenna Bottom Half (Transmit Quality)	1	42	Galvanized M16 Hex Nut	7
6	M6 Stainless Steel Hex Nut	6	43	Galvanized M16 x 35 mm Bound Head Square Neck Bolt	1
7	M6 Stainless Steel Flat Washer	2	44	Galvanized M12 x 40 mm Hex Bolt	12
8	M6-1/4 Stainless Steel Lock Washer	4	45	M12 Flat Washer	24
10	Bottom Feed Support Tube	1	46	M6 x 40 mm Full Thread Hex Bolt	1
11	M12 External Tooth Lock Washer	4	47	Galvanized M12 x 19 mm Special Hex Bolt	4
12	Galvanized M12 x 130 mm Hex Bolt	2			
13	Galvanized Right Hand Channel Cap Mount	1			
14	Galvanized M22 Hex Nut	3			
15	M22 Lock Washer	1			
16	Galvanized M12 x 35 mm Round Head Square Neck Bolt	1			
17	Galvanized M12 x 30 mm Hex Bolt	10			
18	Galvanized Yoke Cap Assembly	1			
19	Galvanized Top Plate Yoke Assembly	1			
24	M22 x 150 mm Hex Bolt	1			



## MAINTENANCE

To ensure that the transmit/receive mount and 2.4 m SMC Offset Antenna is operating efficiently and at an optimum, moderate maintenance is required. We recommend conducting as routine maintenance inspection every six months or as needed, if unusual circumstances occur, such as severe weather conditions, falling objects and vandalism.

The following checklist is provided for your convenience.

### MAINTENANCE INSPECTION CHECKLIST

#### 1 FOUNDATION

Structural Damage

#### 2 TRANSMIT RECEIVE MOUNT

All bolts (if any loosening has occurred tighten and torque - refer to Torque Chart Page 3)

Structural Damage

Corrosion of galvanized steel members (if necessary, repair with cold zinc-rich galvanizing paint)

#### 3 2.4 METER SMC OFFSET ANTENNA

Bolts - M16 round head square neck, securing antenna to mount (Correct torque 47 N-m/35 ft-lb)

Structural Damage

#### 4 BOTTOM FEED SUPPORT TUBE, SIDE FEED SUPPORT STRUTS AND ORU BRACKET

All bolts (if loosening has occurred tighten and torque - refer to Torque Chart on Page 3).

Structural Damage

Corrosion of galvanized steel members (if necessary, repair with cold zinc-rich galvanizing paint)

#### 5 FEED ASSEMBLY

All securing hardware

Structural Damage

Feed Horn Weather Cover - Physical Damage (if damaged, replace to prevent entry of water)

Upon inspection, make necessary repairs and replace any damaged parts. For replacement parts, contact **ANDREW CORPORATION** at the address located on the front of this manual.

**Outline Drawing**  
**Type 243 2.4 Meter Offset SMC Reflector with Transmit/Receive Mount**  
 (All Dimensions in Inches)

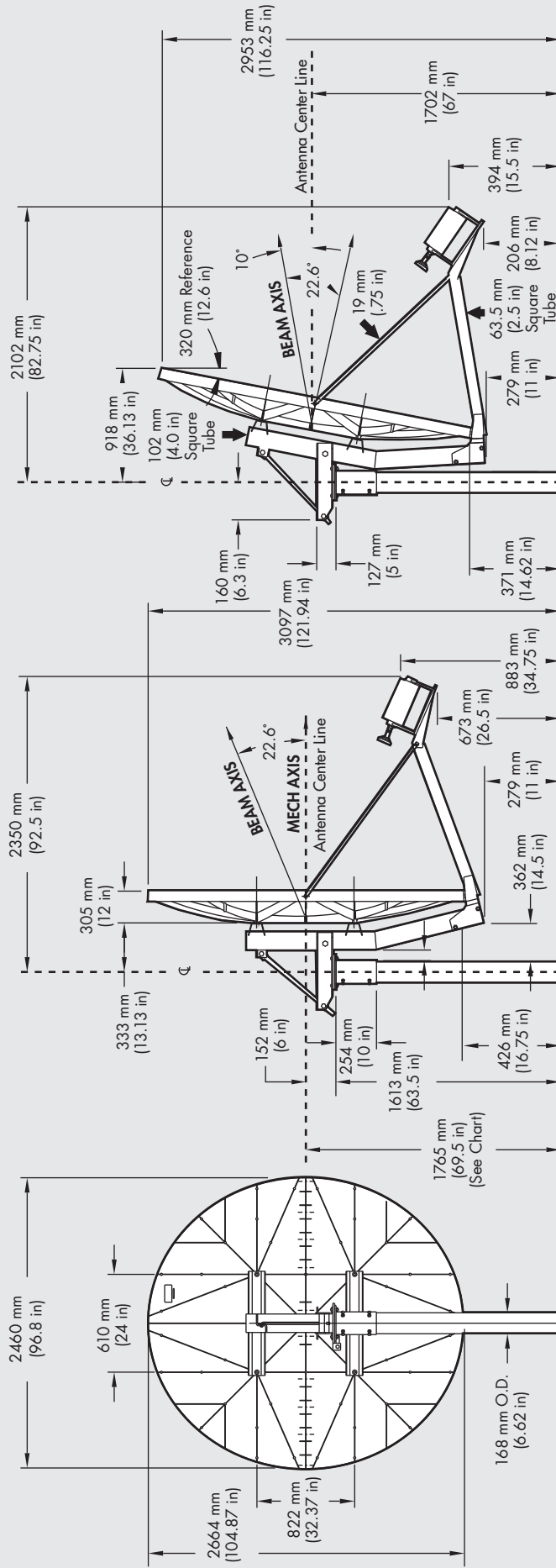

**Notes:**

1. Antenna and mount certified to withstand 125 mph wind.
2. Chart based on A36 (36,000 psi yield) steel and 1.5 stability -1991 Uniform Building Code Table 23G Exposure **B, Cor D** at 0-15° height above ground

152.4 mm (6 in) Ground Pipe	Exposure	125 mph	120 mph	115 mph	110 mph	100 mph
168.1 mm (6.62 in) O.D. x 153.9 mm (6.06 in) I.D. Schedule 40	B	2438 mm (96 in)	-	-	-	-
	C	1575 mm (62 in)	1702 mm (67 in)	1854 mm (73 in)	2032 mm (80 in)	-
	D	-	-	-	1549 mm (61 in)	1854 mm (73 in)
168.1 mm (6.62 in) O.D. x 46.3 mm (5.76 in) I.D. Schedule 80	C	2261 mm (89 in)	2438 mm (96 in)	-	-	-
	D	1702 mm (67 in)	2032 mm (80 in)	-	-	-

# HARDWARE SORTER

All hardware is depicted actual size. Place hardware on picture to verify identity.

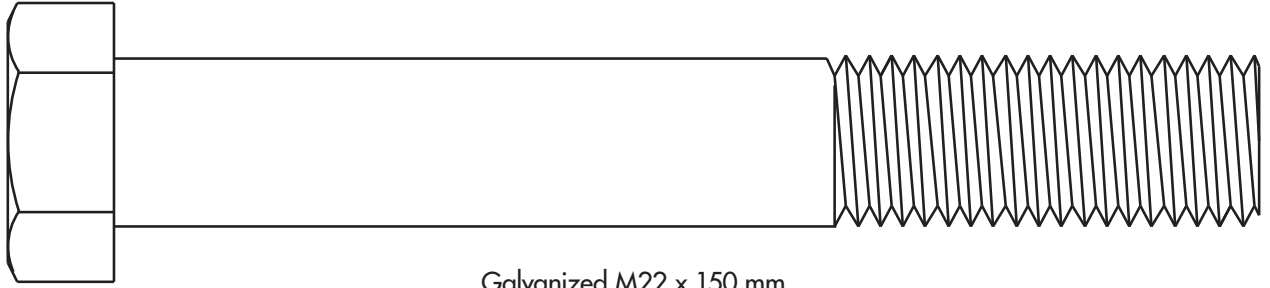

Galvanized M22 x 150 mm  
Hex Head Pivot Bolt  
**Item 24**

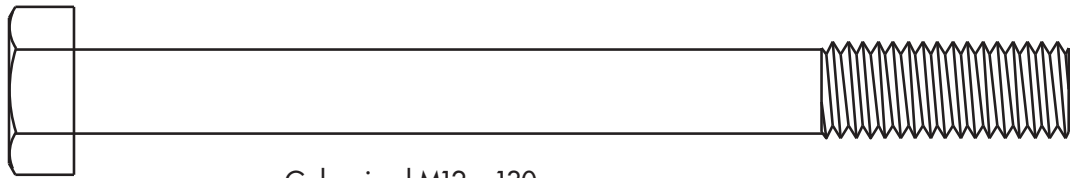

Galvanized M12 x 130 mm  
Class 8.8 Hex Head Bolt  
**Item 12**

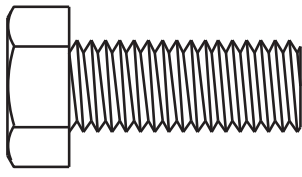

Galvanized M12 x 30 mm  
Class 8.8 Hex Head Bolt  
**Item 17**

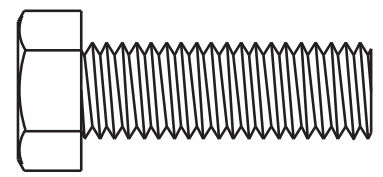
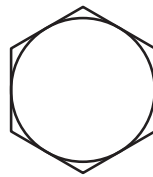

Galvanized M12 x 40 mm  
Hex Head Bolt  
**Item 44**

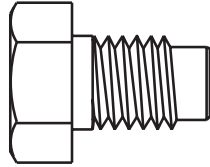
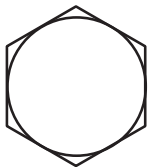

Galvanized M12 x 19 mm  
Hex Head Bolt  
**Item 47**

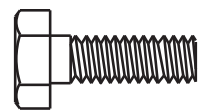
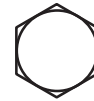

Stainless Steel M6 x 20 mm  
Hex Head Bolt  
**Item 28**

Stainless Steel M6 x 40 mm  
Hex Head Bolt  
**Item 46**



CONTINUED

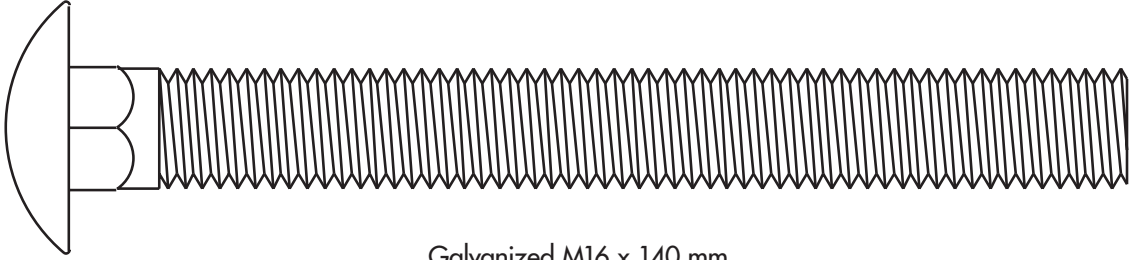

Galvanized M16 x 140 mm  
Round Head Square Neck Bolt  
**Item 2**

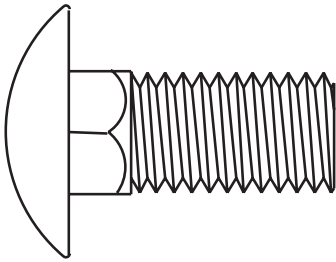

Galvanized M16 x 35 mm  
Round Head Square Neck Bolt  
**Item 43**

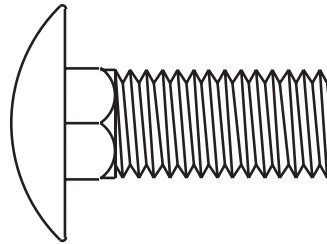
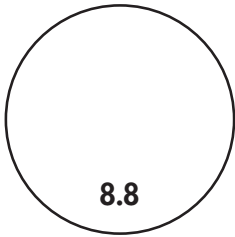

Galvanized M12 x 35 mm  
Round Head Square Neck Bolt  
**Item 16**